



## OIL PALM INDIA LIMITED

(A JOINT VENTURE OF THE GOVT. OF KERALA AND THE GOVT. OF INDIA)

REGD. OFFICE: XIV/130, KOTIAYAM SOUTH P.O, KODIMATHA, KOTTAYAM - 686 013, KERALA PHONE: 2567103, 2567104, 2566882 FAX: 0481-2561442  
GST IN: 32AAAC03695G1ZI, CIN: U01133KL1977SGC002934 Web: www.oilpalmindia.com

OP/SME/POM/2026-27/186

24.04.2026

### RE-TENDER INVITATION

Sub: **Requirement of Spares for Aerobic Feed Pump [Make: Sulzer]**

We invite you to submit your quotation for the following items (**for Palm Oil Mill, Yeroor Estate, Bhartheepuram P. O, Anchal, Kollam Dist., Kerala-691330**) by email in PDF format (indicating our Tender Notice number and due date) to [tendersopil@gmail.com](mailto:tendersopil@gmail.com) on or before the due date on 30.04.2026 up to 02:30 PM and bids shall be opened on same day 03.00 PM.

The items are required of the following details and specifications:

<b>Spares for Sulzer Pump</b>					
<b>Model: CC65x50-160</b>					
<b>QM: 30, H: 20, RPM: 2850</b>					
Sl. No	Name	Part No	Material	Unit	Qty
1	Shaft	501	ASTM A276 TYPE 316	Nos	2
2	Impeller Key	510	ASTM A276 TYPE 316	Nos	4
3	Impeller Nut	512	ASTM A743 GR CF-8M	Nos	6
4	Impeller Semi Open	109	ASTM A743 GR CF-8M	Nos	4
5	Shaft Sleeve	208	ASTM A276 TYPE 316	Nos	4
6	Lantern Ring	215	ASTM A743 GR CF-8M	Nos	2

**Authorized dealership certificate** from OEM (M/s Sulzer India Pvt. Limited) to provided along with quotation.

Place of Delivery: At our Palm Oil Mill, Yeroor Estate, Bhartheepuram P. O, Kollam Dist., Kerala-691330.

Terms of Payment: Within 15 days after receipt subject to acceptance.

Delivery required in case of placement of an Order based on this enquiry: 12 Days.

Your offer should be specific with following break up

1. Basis of Price.
2. Basic Price.
3. GST.
4. Discount Offered %.
5. Other charges % (Like P&F, Freight etc).
6. Delivery Time.

For Oil Palm India Limited

Sd/-

Sr. Manager (Engineering)

## GENERAL CONDITIONS OF THE TENDER

### **1. Price:**

The price should be quoted item wise including GST amount. In case the packing and forwarding charges are involved the same should be shown separately. If no extra charges are mentioned, the quoted rate it will be treated as all-inclusive of GST, Packing and Forwarding, Transportation and other charges of delivery at destination (OPIL). The rates quoted should be shown in both numerical and word form.

### **2. Cess & GST:**

- a) Taxes should be shown separately, wherever applicable
- b) Rates of taxes should be clearly indicated
- c) Cess payable should be indicated separately
- d) Other taxes if any should also be separately indicated

#### **Notes:**

If duty/cess and taxes are not shown specifically, it will be assumed that the rates quoted are inclusive of the same for all purpose. However, in the event of an order arising out of the offer, breakup of taxes and duties (which all mentioned while quoting) be shown separately in the invoice.

### **3. Basis of price:**

The price should be quoted indicating either F.O.R dispatching station or F.O.R destination basis. If the rates are quoted not specifying the basis of rate, the rates will be treated as F.O.R destination.

### **4. Validity of offer:**

The rates quoted should be valid for a minimum period of 30 days from the due date.

### **5. Delivery period:**

A firm delivery date/period should be indicated. Delivery period reckoned shall be treated from the date of release of purchase order. Delivery should be on F.O.R OPIL Basis.

### **6. Firm Price:**

In the event of order price shall be firm till complete execution of the order.

### **7. Payment terms:**

Our payment term is within 15days after receipts subject to acceptance of materials. Offers with other payment terms is liable to the rejected/cost loaded.

**8. Correction and errors:**

Quotation should be free of corrections and errors.

**9. Technical details of offer:**

Manufacturer's name, country of origin and brand/make of the material/materials offered must be clearly specified. Complete / detailed illustrated literature must accompany all quotations.

**10. Penalty for delay:**

Penalty shall be imposed in the form of Liquidated damages at the rate of 0.5% per week or part thereof of the value of the goods for the delayed period beyond the stipulated delivery date in the order duly accepted by vendor. This recovery will be limited to 10% of value of goods without prejudice to the purchaser's other rights.

**11. Rights of acceptance or rejection of tenders:**

OPIL does not bind itself to accept the lowest or any tenders or assign any reason for non-acceptance. It further reserves the right to accept any tenders wholly or in part at its option. It also reserves the right to take 25% more/less of material on any orders placed against this enquiry.

**12. Acceptance of full/part quantity:**

Tenders should clearly have mentioned whether the prices hold good when full quantity of enquiry is not ordered but only a part of it. Unless otherwise mentioned, it would be assumed that the rates hold good even for lesser quantities.

**13. Submission of offers:**

The offers should be submitted by email in PDF format indicating our inquiry number and due date to [tendersopil@gmail.com](mailto:tendersopil@gmail.com) on or before the due date.

For Oil Palm India Limited

Sd/-

Sr. Manager(Engineering)

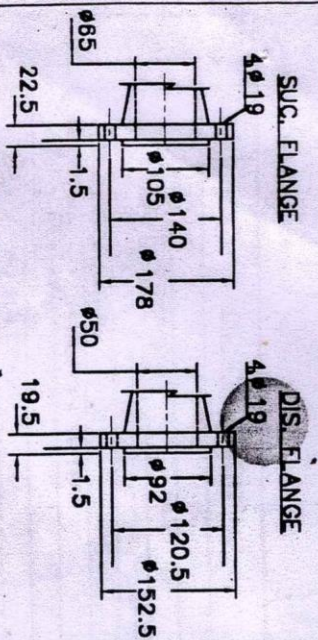

OPERATING DATA		APPROX. WT. IN Kg.
TEMPERATURE (°C)	50	BARE PUMP
FLOW RATE (m <sup>3</sup> /h)	30	BASE PLATE
DIFF. HEAD (m/c)	20	COUPLING
EFFICIENCY %	59	MOTOR
POWER (kw)	2.86	TOTAL

LIQUID: WATER + SLUDGE	DETAILS/DRG.No.	* SCOPE
ACCESSORIES		
MOTOR MAKE	KEC	
kw/rpm	3.1/2850	
FRAME	KH112M	
TYPE	TEFC	
MOUNTING		
FLUSHING		
QUENCHING		
COOLING		
HEATING		
COUPLING		**
COUPLING GUARD		
BASEPLATE & FND.BOLTS		
MOTOR BOLTS		
COMP.FLANGES: SUC/DIS		

\* SCOPE OF SUPPLY:  KHIMLINE  CUSTOMER

NOTES: 1) PUMP CROSS SECTION REF. DRG. No.:CS 4302504

*Approved with Comments*

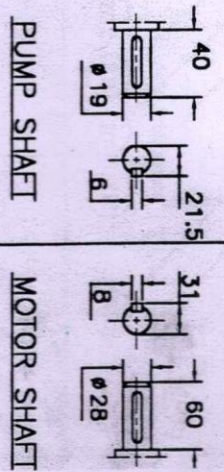
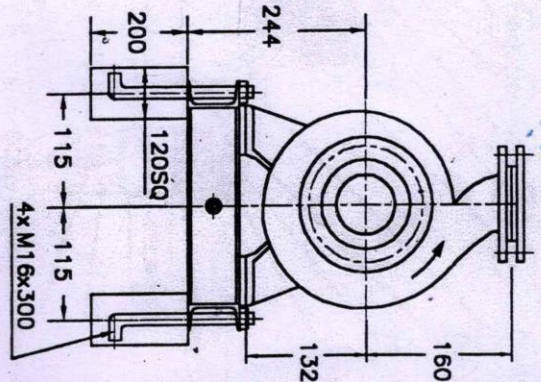
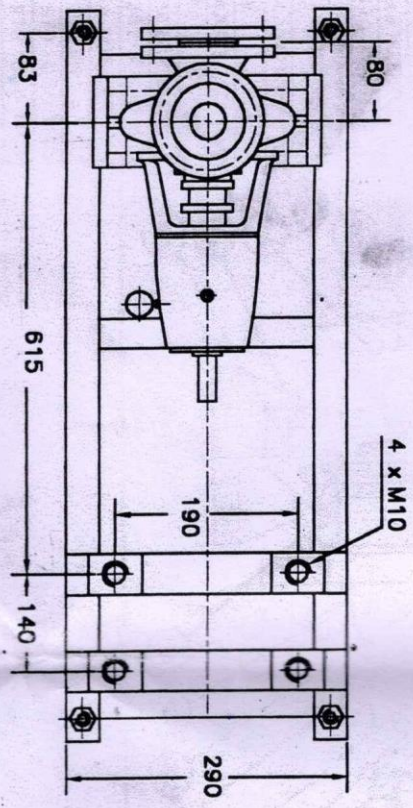
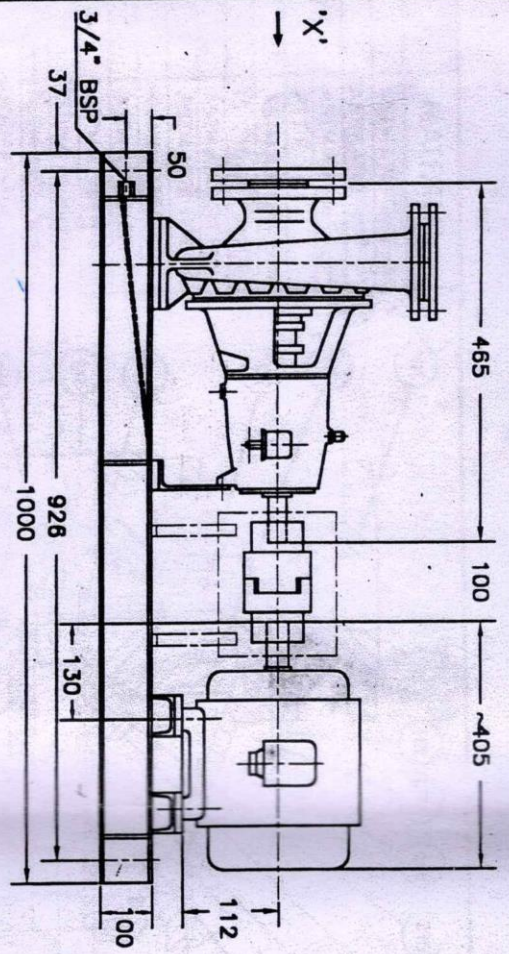

IF IN DOUBT ASK. ALL DIMENSIONS ARE IN mm UNLESS OTHERWISE SPECIFIED.

DRN	R.S.K.	08.07.98
CHKD	RJR	15/7/98
APRD		

CUSTOMER : OIL PALM INDIA LTD.  
 CONSULTANT :  
 ORDER No. : LOI NO. MM .04.09 4800  
 ITEM No. : AEROBIC FEED PUMP  
 PROJECT : PALM OIL MILL  
 SERVICE :  
 W.O. : 9843025  
 DRG.No. : GA 4302504

CC 65x50-160 GENERAL ARRANGEMENT

*Khimline pumps Ltd. INDIA*

REV	DESCRIPTION	SIGN	DATE
-----	-------------	------	------

PART NO.	QTY.	DESCRIPTION	MATERIAL
101	1	CASING	ASTM A723 G.C.F.-8M
106	1	CASING WEAR RING	ASTM A723 G.C.F.-8M
109	1	IMPELLER - <i>SEMIOPEN TYPE</i>	ASTM A723 G.C.F.-8M
110	1	GASKET CASING	PTFE
111/112	1	STUD,NUT CASING TO ADAPTER	ASTM A 276 TYPE-316
113	1	ADAPTER	15:210.Gr. FG:200
201	1	STUFFING BOX COVER	ASTM A723 G.C.F.-8M
202/203	2	STUD,NUT ST. BOX COVER TO GLAND	ASTM A276 TYPE-316
204	1 SET	PACKING RINGS	PTFE
205	1	GLAND	ASTM A723 G.C.F.-8M
208	1	SHAFT SLEEVE	ASTM A276 TYPE-316
211	1	DEFLECTOR	BUNA RUBBER
219	2	PLUG,ST.BOX EXTERNAL FLUSHING (1/4" NPT)	ASTM A 276 TYPE-316
215	1	LANTERN RING	ASTM A723 G.C.F.-8M
216	1	GRUB-SCREW-ST.BOX SELF-FLUSHING	ASTM A276 TYPE-316
501	1	SHAFT	ASTM A276 TYPE-316
502	1	SHAFT KEY COUPLING SIDE	BS 970 080 M40
506	2	DEEP GROOVE BALL BEARING No 6305 (SKF)	STEEL
509	1	GASKET, SHAFT SLEEVE	PTFE
510	1	IMPELLER KEY	ASTM A276 TYPE-316
511	1	GASKET,IMPELLER NUT	PTFE
512	1	IMPELLER NUT	ASTM A723 G.C.F.-8M
515	1	BEARING HOUSING	15:210 Gr. FG:200
517	2	BEARING COVER	15:210 Gr. FG:200
518	8- <del>10</del>	SCREW BEARING COVER TO BEARING HSG.	15:1367 CL. 8-8
519	2	OIL SEAL	BUNA RUBBER
520	2	GASKET, BEARING COVER	OIL PAPER
521/522	4	STUD,NUT BEARING HSG. TO ADAPTER	BS 970 080 M40
523	1	DRAIN PLUG FOR BEARING HSG.	BS 970 080 M40
525	1	CONSTANT LEVEL OILER	PLEXI+GLASS+AI
530	1	BREATHER	PLASTIC
532	1	SUPPORT FOOT	STEEL 15:2062
533	1	HEX SCREW SUPPORT FOOT TO BEARING HSG.	15:1367 CL. 8-8
104	1	GASKING-BRAIN-PLUG SIZE-1/4" NPT	ASTM A276 TYPE-316
806	1	FLEXIBLE COUPLING *	C1
544	1	COUPLING GUARD	STEEL 15:2062
124	1	BASE PLATE	A182 F 316
	1/1	COMPANION FLANGE SUC./DIS.	CL.8-8 - CL.8
	4/4	HEX.SCREW-NUT, COMP.FLANGE SUC./DIS.	CL.8-8 - CL.8
	1 1	GASKET, COMP.FLANGE SUC./DIS.	CAF-40

\* LOVE JOY : RRL 095  
OR  
UTKARSH : USS 45

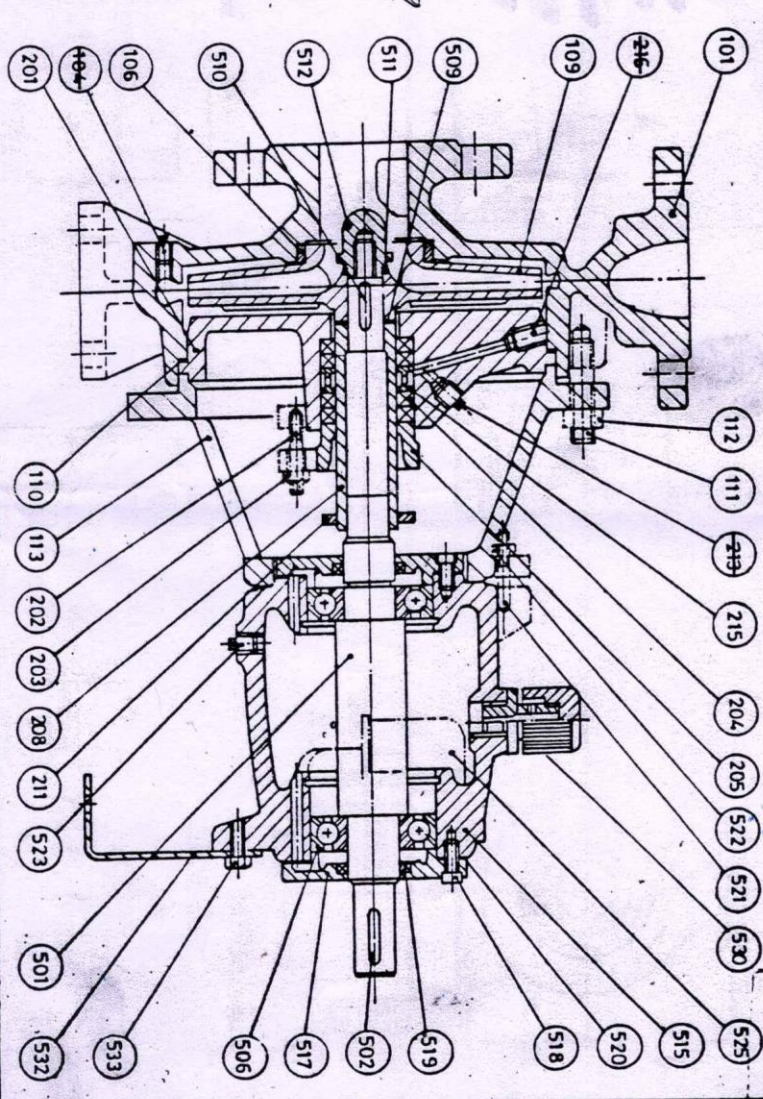

*Approved with comments*

\* AEROBIC FEED PUMP

AUXILIARY REQUIREMENT  
1) SEALING : GLAND PACKING  
2) FLUSHING : SELF EXTERNAL

REV.	WO : 9843025	ITEM No. :	*	DRG No:CS 4302504
DRAWN R.S.K 13.7.98	CC65x50-160	PUMP CROSS SECTION		
CHECKED <i>PKR</i>		<i>Schimline pumps Ltd.</i>		
APRD.				