



# OIL PALM INDIA LIMITED

(A JOINT VENTURE OF THE GOVT. OF KERALA AND THE GOVT. OF INDIA)

REGD. OFFICE: XIV/130, KOTIAYAM SOUTH P.O, KODIMATHA, KOTTAYAM - 686 013, KERALA PHONE: 2567103, 2567104, 2566882 FAX: 0481-2561442  
GST IN: 32AAAC03695G1ZI, CIN: U01133KL1977SGC002934 Web: www.oilpalmindia.com

OP/SME/POM/2026-27/189

24.04.2026

## RE-TENDER INVITATION

Sub: **Requirement of Spares for Effluent Discharge Pump (Make: Sulzer)**

We invite you to submit your quotation for the following items (**for Palm Oil Mill, Yeroor Estate, Bhartheepuram P. O, Anchal, Kollam Dist., Kerala-691330**) by email in PDF format (indicating our Tender Notice number and due date) to [tendersopil@gmail.com](mailto:tendersopil@gmail.com) on or before the due date on 01.05.2026 up to 02:30 PM and bids shall be opened on same day 03.00 PM.

The items are required of the following details and specifications:

<b>Spares for Sulzer Pump</b>					
<b>Model: CC65x50-250</b>					
<b>Sr.No: 27817, QM-30, H: 60, RPM-2890</b>					
<b>Sl. No</b>	<b>Name</b>	<b>Part No</b>	<b>Material</b>	<b>Unit</b>	<b>Qty</b>
1	Shaft	501	ASTM A276 TYPE 316	Nos	1
2	Impeller Key	510	BS 970 080 M40	Nos	2
3	Impeller Nut	512	IS 210 Gr FG 200	Nos	4
4	Shaft Sleeve	208	ASTM A743 Gr CF-8M	Nos	4
5	Bearing Housing	515	IS 210 Gr FG 200	Nos	1
6	Bearing Cover	517	IS 210 Gr FG 200	Nos	2
7	Lantern Ring	215	IS 210 Gr FG 200	Nos	2

**Authorized dealership certificate** from OEM(M/s Sulzer India Pvt.Limited) to provided along with quotation.

Place of Delivery: At our Palm Oil Mill, Yeroor Estate, Bhartheepuram P. O, Kollam Dist., Kerala-691330.

Terms of Payment: Within 15 days after receipt subject to acceptance.

Delivery required in case of placement of an Order based on this enquiry: 12 Days.

Your offer should be specific with following break up

1. Basis of Price.
2. Basic Price.
3. GST.
4. Discount Offered %.
5. Other charges % (Like P&F, Freight etc).
6. Delivery Time.

For Oil Palm India Limited

Sd/-  
Sr.Manager (Engineering)

**GENERAL CONDITIONS OF THE TENDER**

**1. Price:**

The price should be quoted item wise including GST amount. In case the packing and forwarding charges are involved the same should be shown separately. If no extra charges are mentioned, the quoted rate it will be treated as all-inclusive of GST, Packing and Forwarding, Transportation and other charges of delivery at destination (OPIL). The rates quoted should be shown in both numerical and word form.

**2. Cess & GST:**

- a) Taxes should be shown separately, wherever applicable
- b) Rates of taxes should be clearly indicated
- c) Cess payable should be indicated separately
- d) Other taxes if any should also be separately indicated

**Notes:**

If duty/cess and taxes are not shown specifically, it will be assumed that the rates quoted are inclusive of the same for all purpose. However, in the event of an order arising out of the offer, breakup of taxes and duties (which all mentioned while quoting) be shown separately in the invoice.

**3. Basis of price:**

The price should be quoted indicating either F.O.R dispatching station or F.O.R destination basis. If the rates are quoted not specifying the basis of rate, the rates will be treated as F.O.R destination.

**4. Validity of offer:**

The rates quoted should be valid for a minimum period of 30 days from the due date.

**5. Delivery period:**

A firm delivery date/period should be indicated. Delivery period reckoned shall be treated from the date of release of purchase order. Delivery should be on F.O.R OPIL Basis.

**6. Firm Price:**

In the event of order price shall be firm till complete execution of the order.

**7. Payment terms:**

Our payment term is within 15days after receipts subject to acceptance of materials. Offers with other payment terms is liable to the rejected/cost loaded.

**8. Correction and errors:**

Quotation should be free of corrections and errors.

**9. Technical details of offer:**

Manufacturer's name, country of origin and brand/make of the material/materials offered must be clearly specified. Complete / detailed illustrated literature must accompany all quotations.

**10. Penalty for delay:**

Penalty shall be imposed in the form of Liquidated damages at the rate of 0.5% per week or part thereof of the value of the goods for the delayed period beyond the stipulated delivery date in the order duly accepted by vendor. This recovery will be limited to 10% of value of goods without prejudice to the purchaser's other rights.

**11. Rights of acceptance or rejection of tenders:**

OPIL does not bind itself to accept the lowest or any tenders or assign any reason for non-acceptance. It further reserves the right to accept any tenders wholly or in part at its option. It also reserves the right to take 25% more/less of material on any orders placed against this enquiry.

**12. Acceptance of full/part quantity:**

Tenders should clearly have mentioned whether the prices hold good when full quantity of enquiry is not ordered but only a part of it. Unless otherwise mentioned, it would be assumed that the rates hold good even for lesser quantities.

**13. Submission of offers:**

The offers should be submitted by email in PDF format indicating our inquiry number and due date to [tendersopil@gmail.com](mailto:tendersopil@gmail.com) on or before the due date.

For Oil Palm India Limited

Sd/-

Sr. Manager(Engineering)

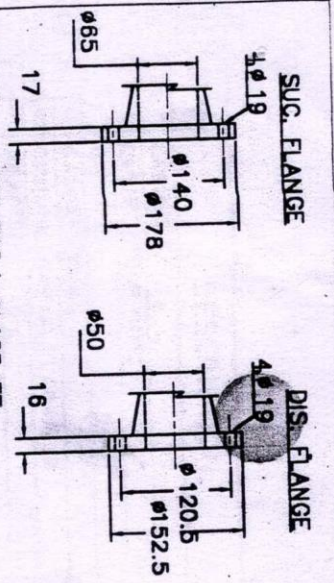

RATING: ANSI B16.1 CL125-FF  
 DRILLING: ANSI B16.1 CL125 FF

OPERATING DATA		APPROX. WT. IN Kg.	
TEMPERATURE (°C)	30	BARE PUMP	77
FLOW RATE (m <sup>3</sup> /h)	30	BASE PLATE	60
DIFF. HEAD (mic)	60	COUPLING	6
EFFICIENCY %	46	MOTOR	134
POWER (kw)	10.66	TOTAL	277

LIQUID: WATER	ACCESSORIES	DETAILS/DRG.No.	* SCOPE
MOTOR MAKE	KEC		<input checked="" type="checkbox"/>
kw/rpm	15/2890		<input checked="" type="checkbox"/>
FRAME	KH160M		<input checked="" type="checkbox"/>
TYPE	TEFC		<input checked="" type="checkbox"/>
MOUNTING			<input checked="" type="checkbox"/>
FLUSHING			<input checked="" type="checkbox"/>
QUENCHING			<input checked="" type="checkbox"/>
COOLING			<input checked="" type="checkbox"/>
HEATING			<input checked="" type="checkbox"/>
COUPLING GUARD			<input checked="" type="checkbox"/>
BASEPLATE & FND.BOLTS			<input checked="" type="checkbox"/>
MOTOR BOLTS			<input checked="" type="checkbox"/>
COMP.FLANGES: SUC/DIS			<input checked="" type="checkbox"/>

\* SCOPE OF SUPPLY:  KHIMLINE  CUSTOMER  
 NOTES: 1) PUMP CROSS SECTION REF. DRG. No.:CS4302505

\*\* LOVEJOY RRL-110 OR UTKARSH USS-110

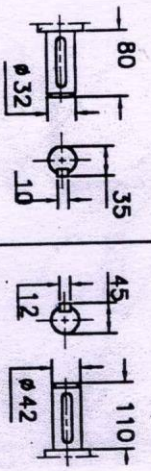
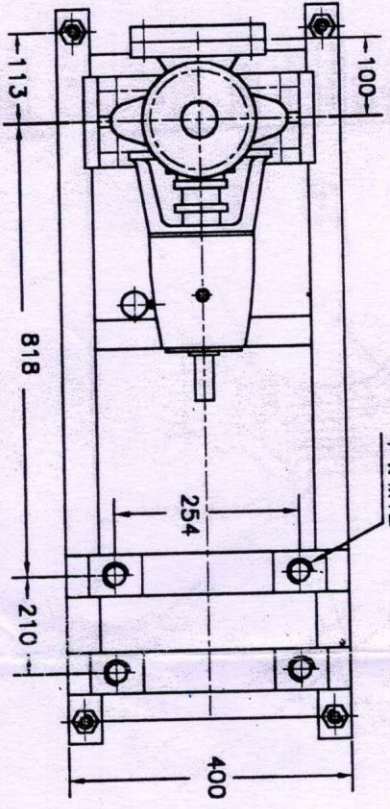
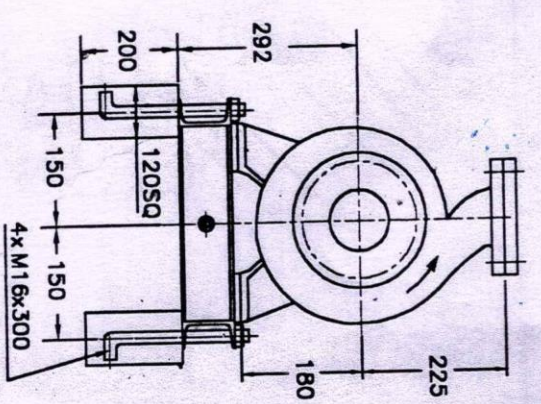
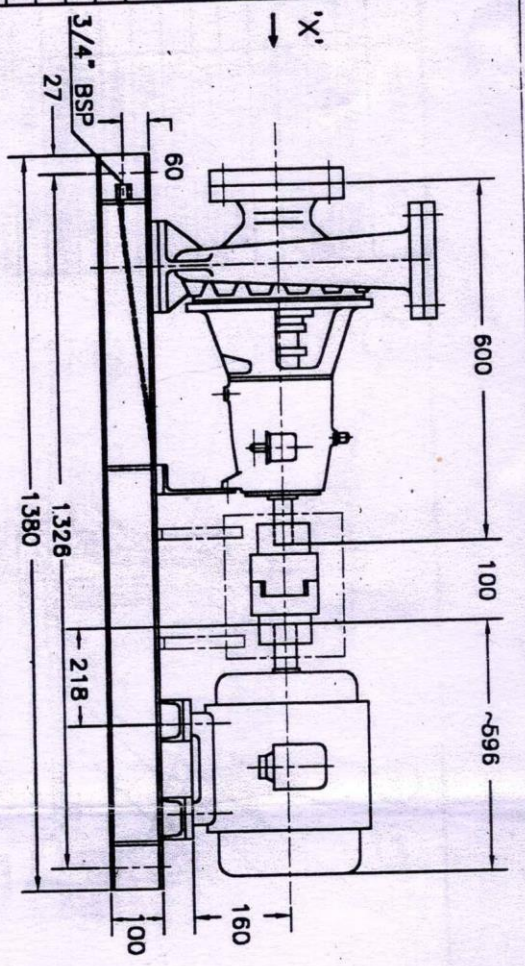

IF IN DOUBT ASK. ALL DIMENSIONS ARE IN mm UNLESS OTHERWISE SPECIFIED.

DRN	R.S.K.	08.07.98
CHKD	RSR	13/11/98
APRD		

CUSTOMER : OIL PALM INDIA LTD.  
 CONSULTANT :  
 ORDER No. : LOI NO. MM.04.09 4800 DATE : 11.03.98  
 ITEM No. : TREATED EFFLUENT DISCHARGE QUANTITY : 02  
 PROJECT : PALM OIL MILL  
 SERVICE :  
 W.O. : 9843025 DRG.No. : GA 4302505

CC 65x50-250 GENERAL ARRANGEMENT

**Khimline pumps Ltd. 100**

REV	DESCRIPTION	SIGN	DATE

*Handwritten signature and notes:*  
 Khimline pumps Ltd. 100  
 100

PART No.	QTY.	DESCRIPTION	MATERIAL
101	1	CASING	IS:210.Gr.F.G:200
106	1	CASING WEAR RING	ASTM A276 TYPE316
109	1	IMPELLER	ASTM A276 TYPE316
110	1	GASKET CASING	PTFE
111/112	1	STUD,NUT CASING TO ADAPTER	BS 970 080 M40
113	1	ADAPTER	IS:210.Gr.F.G:200
201	1	STUFFING BOX COVER	IS:210.Gr.F.G:200
202/208	2	STUD,NUT ST. BOX COVER TO GLAND	ASTM A 276, TYPE 316
204	1 SET	PACKING RINGS	PTFE
205	1	GLAND	IS:210.Gr.F.G:200
208	1	SHAFT SLEEVE	ASTM A276 TYPE316
211	1	DEFLECTOR	BUNA RUBBER
212	2	PLUG,ST.BOX EXTERNAL FLUSHING (1/4" NPT)	BS 970 080 M40
215	1	LANTERN RING	IS:210.Gr.F.G:200
216	1	GRUBSCREW ST.BOX SELF FLUSHING	IS:1967 CL.8-8
501	1	SHAFT	ASTM A276 TYPE316
502	1	SHAFT KEY COUPLING SIDE	BS 970 080 M40
506	2	DEEP GROOVE BALL BEARING No 6308 (SKF)	STEEL
509	1	GASKET, SHAFT SLEEVE	PTFE
510	1	IMPELLER KEY	BS 970 080 M40
511	1	GASKET,IMPELLER NUT	PTFE
512	1	IMPELLER NUT	IS:210.Gr.F.G:200
515	1	BEARING HOUSING	IS:210.Gr.F.G:200
517	2	BEARING COVER	IS:210 Gr.FG:200
518	8-10	SCREW BEARING COVER TO BEARING HSG.	IS 1367 CL. 8-8
519	2	OIL SEAL	BUNA RUBBER
520	2	GASKET, BEARING COVER	OIL PAPER
521/522	4	STUD,NUT BEARING HSG. TO ADAPTER	BS 970 080 M40
523	1	DRAIN PLUG FOR BEARING HSG.	BS 970 080 M40
525	1	CONSTANT LEVEL OILER	PLEXI+GLASS+AI
530	1	BREATHER	PLASTIC
532	1	SUPPORT FOOT	STEEL IS 2062
533	1	HEX.SCREW SUPPORT FOOT TO BEARING HSG.	IS 1367 CL. 8-8
104	1	GASKET, BEARING COVER	BS 970 080 M40
806	1	FLEXIBLE COUPLING *	CL
544	1	COUPLING GUARD	STEEL IS 2062
124	1	BASE PLATE	STEEL IS 2062
1/1	1/1	COMPANION FLANGE SUC./DIS.	STEEL IS 2062
4/4	4/4	HEX.SCREW-NUT, COMP.FLANGE SUC./DIS.	CL. 8-8 - CL. 8
1	1	GASKET, COMP.FLANGE SUC./DIS.	CAF-40

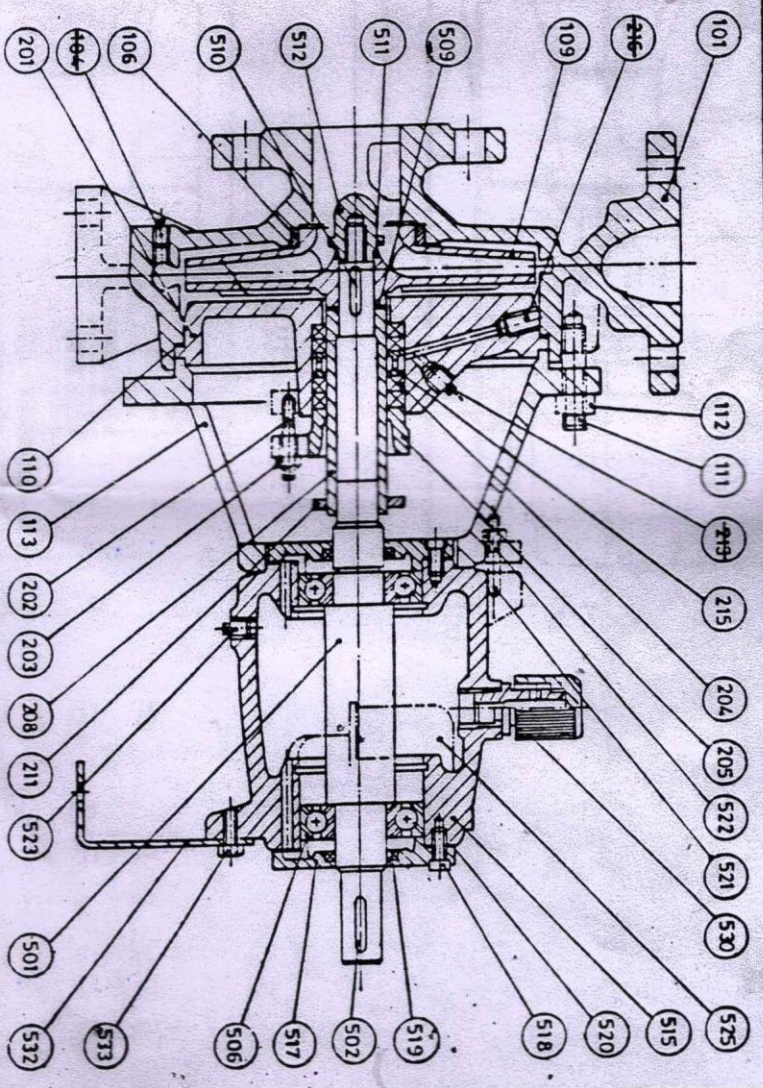

\* TREATED EFFLUENT DISCHARGE

AUXILIARY REQUIREMENT  
 1) SEALING : GLAND PACKING  
 2) FLUSHING : SELF EXTERNAL

REV.		W/O : 9843025	ITEM No. : *	DRG.No: CS 4302505
DRAWN	R.S.K. 13798	CC 65 x 50 - 250	PUMP CROSS SECTION	
CHECKED	R.S.K. 13798			
APRD	R.S.K. 13798			

*Skimline pumps Ltd. 100*